

**5 YEAR  
WARRANTY**

**75W**  
**Phase Cut**  
**Dimmable**  
**LED Driver**  
with PWM  
Output

**Features of the:  
PDV-75 Series**

-  Constant Voltage PWM Output
-  AC Input Range: 200-240VAC
-  Protections:
  - Short Circuit
  - Over Load
  - Over Current
  - Over Temperature
-  Class II Power Supply
-  IP20 Design For Indoor Installation
-  Cooling by Free Air Convection
-  Factory Fitted Flex and Plug
-  Compatible with Most Leading and Trailing Edge Dimmers



Model		PDV-75-12	PDV-75-24
Output	DC voltage	12V	24V
	Voltage tolerance	±0.5V (see Note 2.)	
	Rated current	6.25A	3.125A
	Rated power	75W	
Input	Voltage range	200-240VAC	
	Frequency range	47~63HZ	
	Power factor	PF ≥ 0.98/200VAC PF ≥ 0.98/230VAC PF ≥ 0.98/240VAC (Full loading)	
	Full load efficiency (Typ.)	85%	85%
	AC current (Max.)	0.55A	0.55A
	Leakage current	<0.50mA	
	Inrush current	(Typ.): Cold Start 68A (twidh=130us measured at 50% Ipeak) at 230VAC	
	MAX. No. of drivers on 16A Circuit breaker	4 units (circuit breaker of type B) / 7 units (circuit breaker of type C) at 230VAC	
	Protection	Short circuit	Shut down o/p voltage, re-power on to recover after fault condition is removed
Over loading (Note 4.)		≤ 120%: Hiccup mode recovers automatically after fault condition is removed	
Over current		≤ 1.2 *Iout	
Over temperature		100°C± 10°C shut down o/p voltage, re-power on to recover	
Environment	Working TEMP.	-40~+70°C (refer to de-rating curve)	
	Working humidity	20-90%RH, non-condensing	
	Storage TEMP, humidity	-40~+80°C, 10-95%RH	
	TEMP. coefficient	±0.03%/°C (0-50°C)	
	Vibration	10-500Hz, 2G 10min./1 cycle, period for 72min, each along X, Y, Z axes	
Safety & EMC	Safety standards	EN61347-1 EN61347-2-13	
	Withstand voltage	I/P-O/P: 3.75KVAC	
	Isolation resistance	I/P-O/P: 100MΩ/500VDC/25°C/70%RH	
	EMC emissions (Note 3.)	EN55015, EN61000-3-2,3 (≥60% loading)	
Others	Net. weight	0.45KG	
	Size	180*60*35mm (L*W*H)	
	Packing	355*2150*215mm outside carton 20PCS/CTN	
Notes	<ol style="list-style-type: none"> <li>All parameters NOT specially mentioned are measured at 230VAC input at rated load and 25°C of ambient temperature.</li> <li>Tolerance: Includes set up tolerance, line regulation and load regulation.</li> <li>The power supply is considered as a component that is operated in combination with final equipment. EMC performance could be affected by the complete installation. Original equipment manufacturers may need to conduct additional EMC testing and certification on the final equipment.</li> <li>Loading range from 10% to 100%.</li> <li>Specifications are subject to change without prior notice. Contact your supplier to confirm any critical parameters.</li> </ol>		

## Dimming Operation

- Dimming is with installing a leading edge, or trailing edge dimmer across the AC input.
- Compatible with most leading edge and trailing edge dimmers. Australian compatibility table available on request.
- It is recommended that a dimmer, with a power rating three times higher than that of the rated output of the LED driver is used.

## Mechanical Specification

- Connect LED to LED driver via screw terminals under removable cover. Positive (LED+), Negative (LED-).
- Suggested output wire diameter: 0.5-2.5mm<sup>2</sup>.
- Incorrect wiring could result in damage to the power supply, which is not covered by the warranty.
- Contact your supplier with specific input, or output configuration requests.

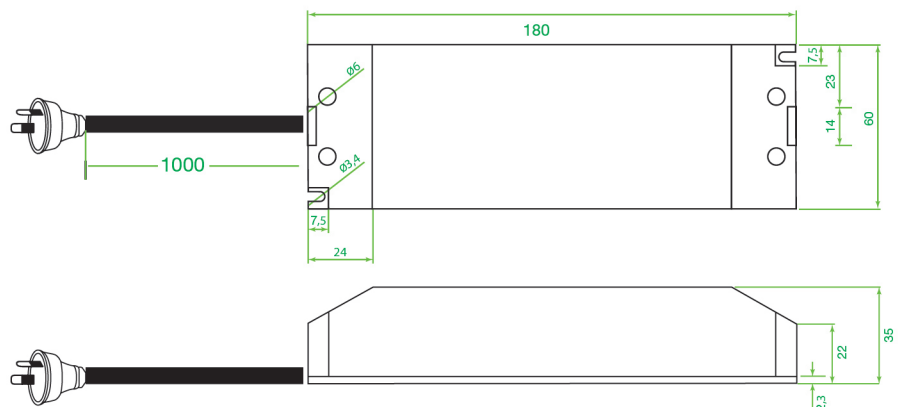

## Single Driver Connection Diagram

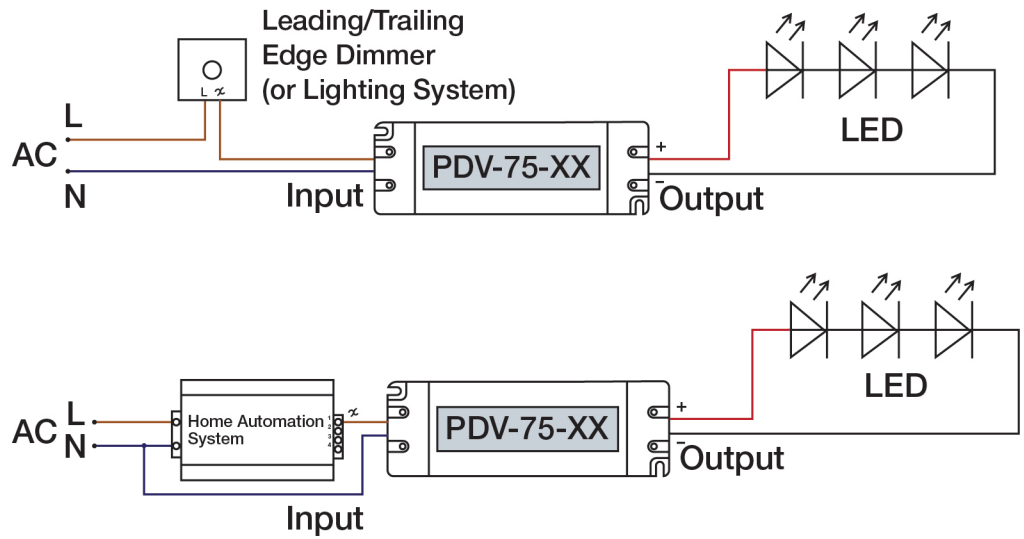

## Multiple Drivers Connection Diagram

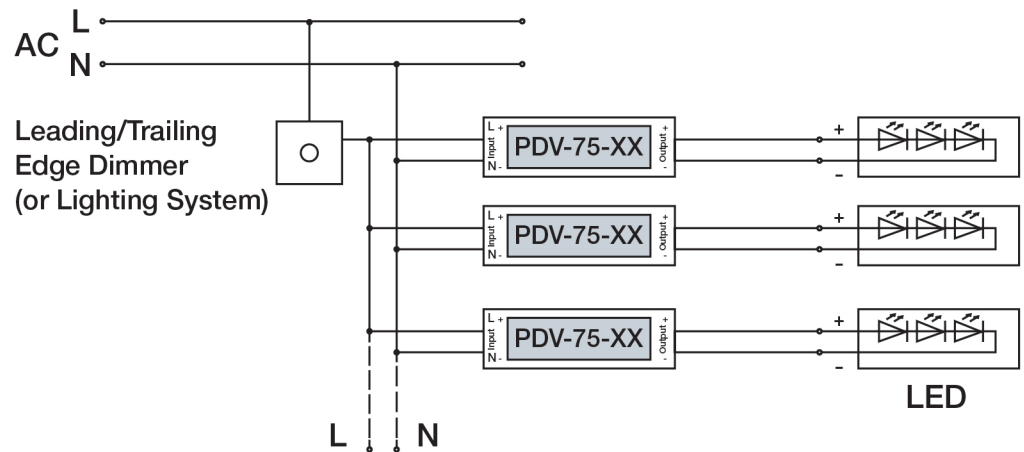

## De-rating Curve

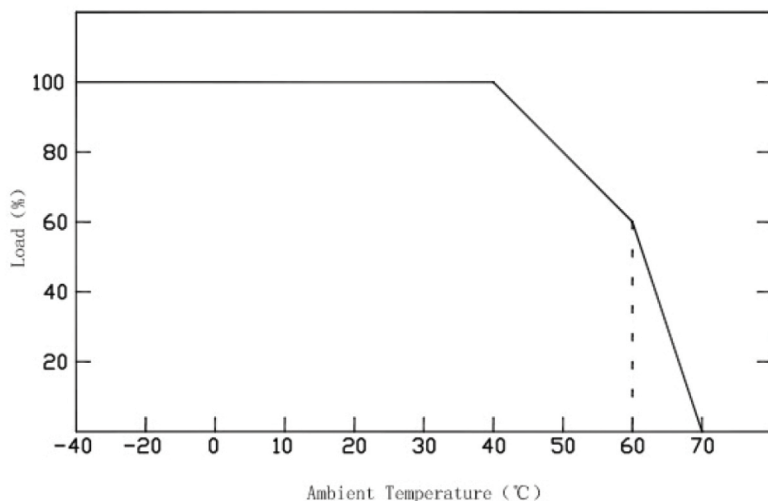

- If being used in higher ambient temperatures, ensure the load on the LED driver is de-rated in accordance with this chart. Failure to do so could lead to a premature failure, which is not covered by the warranty.

## Important

- 1) This LED driver should be installed by a qualified electrician.
- 2) Please make sure the LED driver is installed with adequate ventilation around it to allow for heat dissipation.
- 3) Ensure that all wiring is correct before testing in order to avoid damage to the LED driver, or the LEDs.